



Adventure Microwave-VNA: Repairing and Operating an HP8510

Prof. Dr. Thomas Baier
DG8SAQ

Technische Hochschule Ulm
University of Applied Sciences
Prittwitzstrasse 10
89075 Ulm

E-Mail: thomas.baier@thu.de

Thanks to

Kurt Poulsen, OZ7OU

Claudio Girardi, IN3OTD / DK1CG

Wayne Knowles †, ZL2BKC

And the members of...

<https://groups.io/g/HP-Agilent-Keysight-equipment>

<https://groups.io/g/svna>

My Deram: HP8510 – 26,5GHz VNA



NETWORK ANALYZERS

Microwave Network Analyzers, 45 MHz to 100 GHz

8510 Series

- 45 MHz to 100 GHz frequency range
- “Real Time” error-corrected measurements
- 60 dB effective directivity and source match
- 70 dB to 100 dB dynamic range
- 0.001 dB, 0.01 degree, 0.01 nanosecond measurement resolution
- Time domain analysis

Ordering Information

HP 8510B Network Analyzer
Option 010 Time Domain Capability
HP 8514B S-parameter Test Set
Option 001 add IF Switching
HP 8340A Synthesized Sweeper

Price
\$33,800
9,800
27,000
add 2,000
\$69,100

20GHz Version: \$ 141 700,-

abt. 1985

Even used still very expensive...



HP 8510C NETZWERKANALYSATOR/8516A S-PARAMETER TESTSET/83621A SYNTHETISIERTE FEGERMASCHINE

Artikelzustand: **Gebraucht**

Preis: **US \$15.000,00**
Ca. EUR 13.902,41

Sofort-Kaufen

In den Warenkorb

Preisvorschlag:

Preisvorschlag senden

[Auf die Beobachtungsliste](#)

Rücknahmen akzeptiert

7 Beobachter

Versand: **KOSTENLOS** Expedited International Shipping | [Weitere Details](#)
Standort: direct from, Japan

Lieferung: Lieferung zwischen **Mo, 30. Jan** und **Mo, 6. Feb** bei heutigem Zahlungseingang ⓘ

Rücknahmen: 60 Tag Rückgabe | [Weitere Details](#)

... and hard to get in Europe!

Vector-Network-Analyzer (VNA)

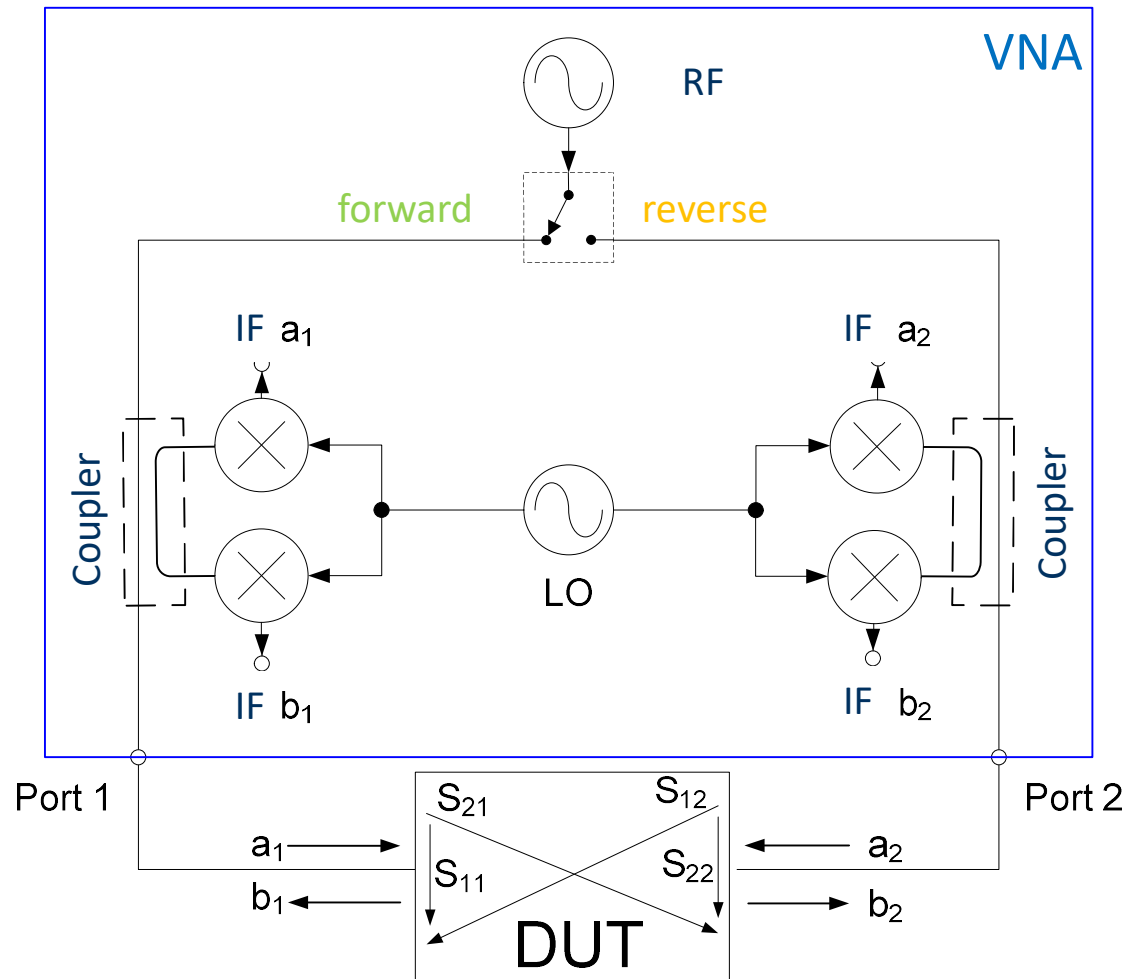

We want to measure the scattering parameters S of a test object
= **Device Under Test** :

$$S_{11} = \frac{b_1}{a_1}$$

$$S_{21} = \frac{b_2}{a_1}$$

forward

$$S_{12} = \frac{b_1}{a_2}$$

$$S_{22} = \frac{b_2}{a_2}$$

reverse

HP8510 System - Versions



HP8510A

- Monochrome-Vector-Display
- Operating System in **Magnetic Bubble Memory** 😞
- Mag-Tape Storage 😊
- 2 Display Channels

HP8510C

- Color CRT
- Operating System in EEPROM
- 3,5" Floppy Disk
- 4 Display Channels
- **Expensive** 😞



HP8510B

- Monochrome-Vector-Display
- Operating System in EEPROM
- Mag-Tape Storage 😊
- 2 Display Channels

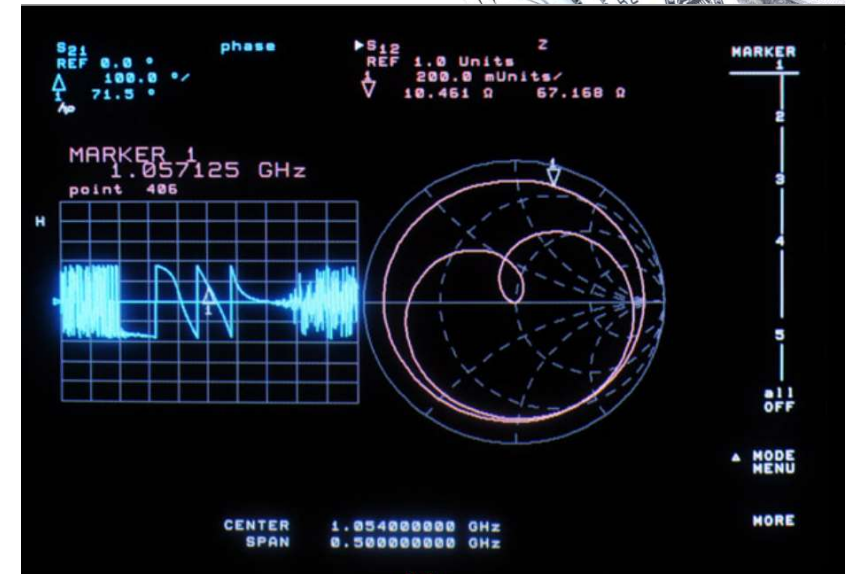

https://www.hpmemoryproject.org/technics/bench/8510/bench_8510_home.htm

HP8510 Units (1)



HP85101 Display/Processor

- Display
- Processor
- Data Storage
- GPIB-Interface

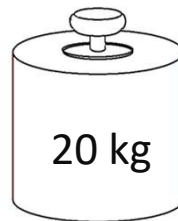

HP85102 Receiver Backend

- IF-Unit
- ADC
- PLL

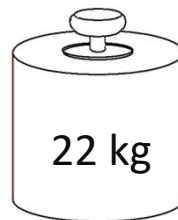

HP8510 Units (2)



HP8514/8515/8516 Test Set

- Bridges
- RF-Switch
- 1st Mixers/Samplers
- LO

HP8514: 45MHz-20GHz
 HP8515: 45MHz-26,5GHz
 HP8516: 45MHz-40GHz



21 kg

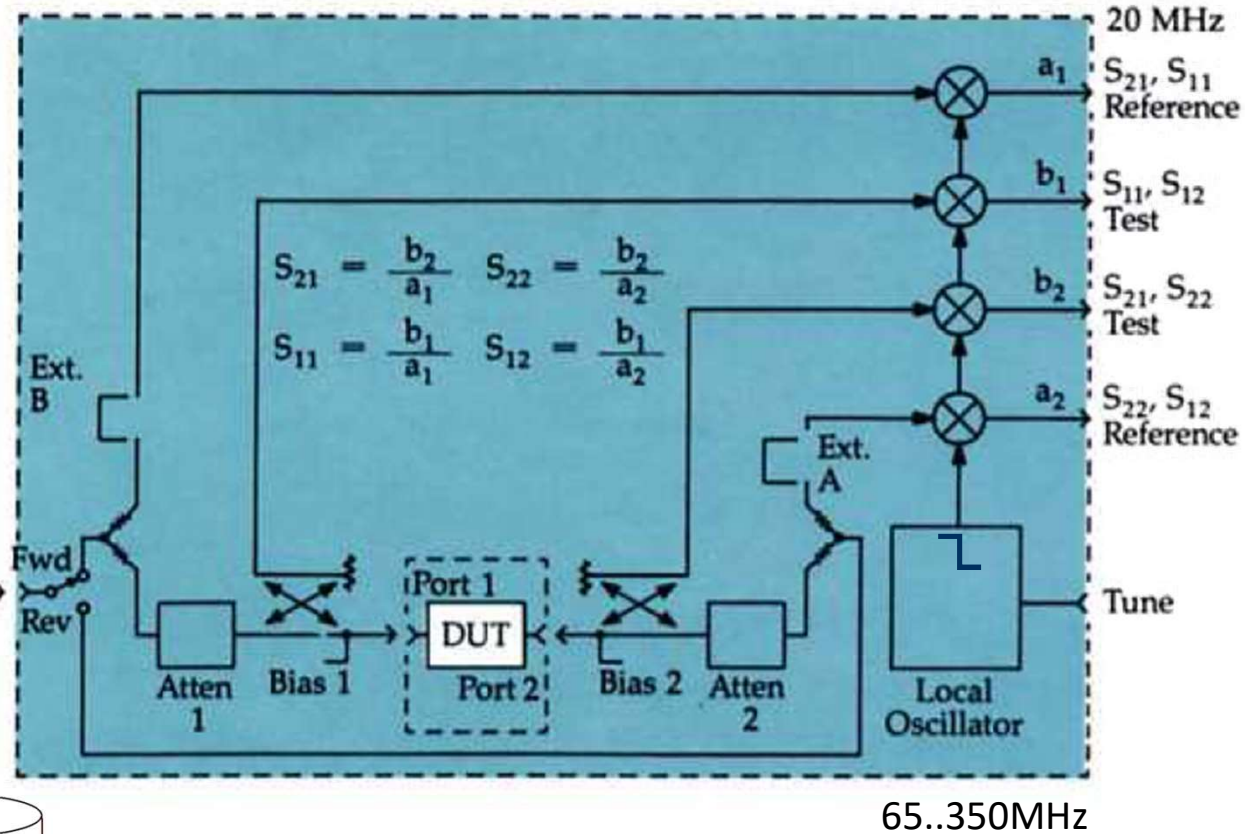

HP8510 Units (3) - RF-Generators



HP8350B

- Free Running Sweeper
- 10MHz-26,5GHz
(depending on Plug-in)

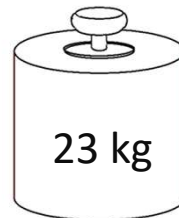

or

HP8340 / HP8341

- PLL Sweeper

HP8340: 10MHz-26,5GHz

HP8341: 10MHz-20GHz

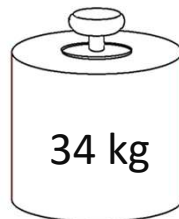

November 2015: The Adventure begins...



- HP 8350B / HP 83592A - Sweep Generator 10 MHz - 20 GHz
- From Ebay, ex German Army
- € 1249,-
- *Chain Smoker* 



Testing Generator on 6GHz Bandpass Filter using Diode Detectors and Directional Coupler



DG85AQ Vector Network Analyzer Software

27.03.2016 18:09:13 HP8350B-6GHz BPF simultaneous S11+S21

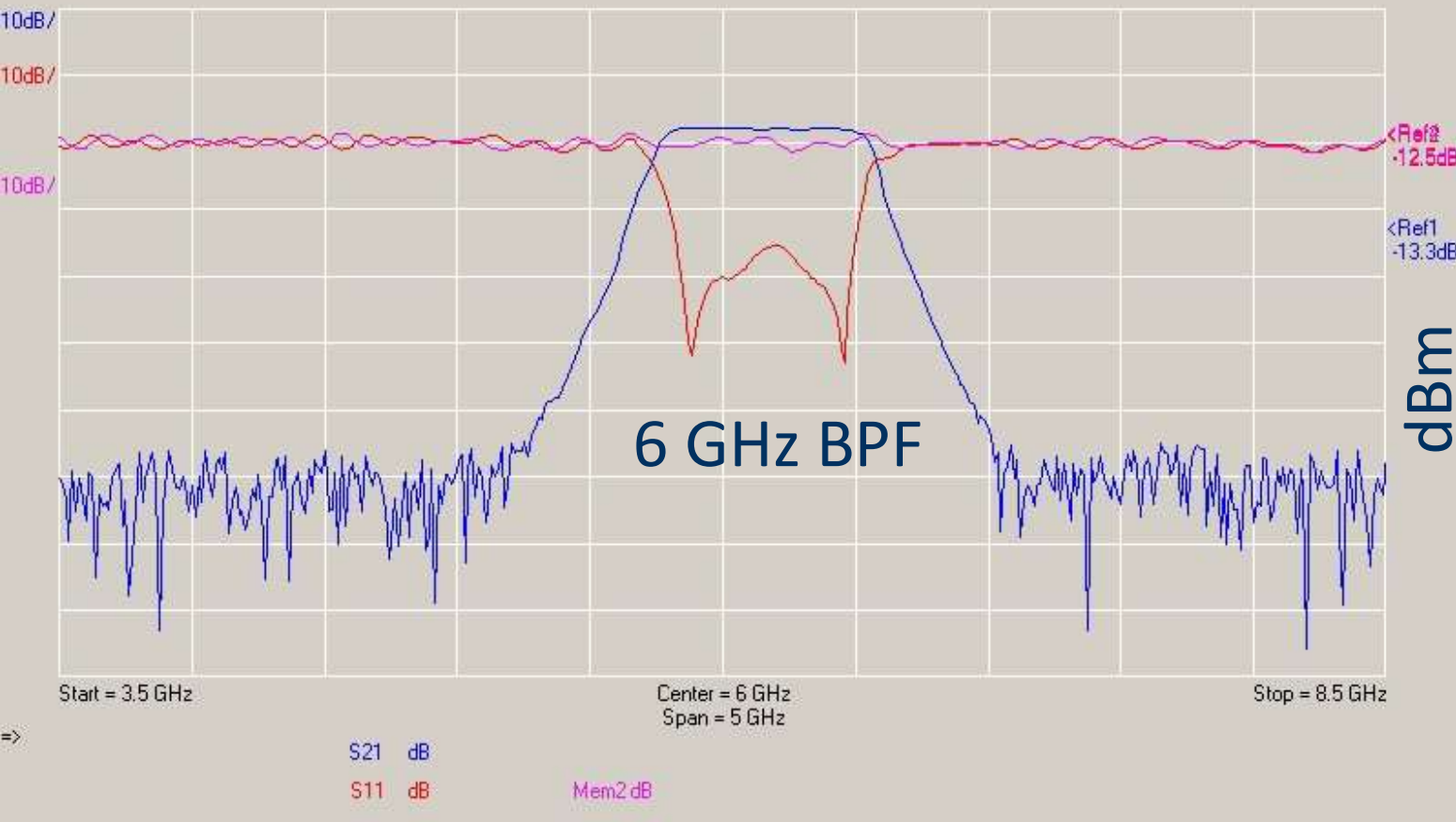

HP8350B flawless
(except for smell) 😊

February 2017: The Adventure continues



Ihr Gebot von US \$313,00 war das höchste! Als Nächstes geht es zum Bezahlen.

Jetzt zahlen

Bitte bezahlen Sie , um Ihren Kauf abzuschließen.

Ihr Artikel - Ihr Erfolg

Agilent HP 8510B Network Analyzer System w/ Display Section [READ](#)



Höchstgebot: **US \$313,00**

Gut gemacht! Sobald Sie bezahlt haben, gehört dieser Artikel Ihnen.

Jetzt zahlen

42kg !!!

Problem in Power Supply?

Should be fixable...

„doesn't power up“



Erster Dämpfer

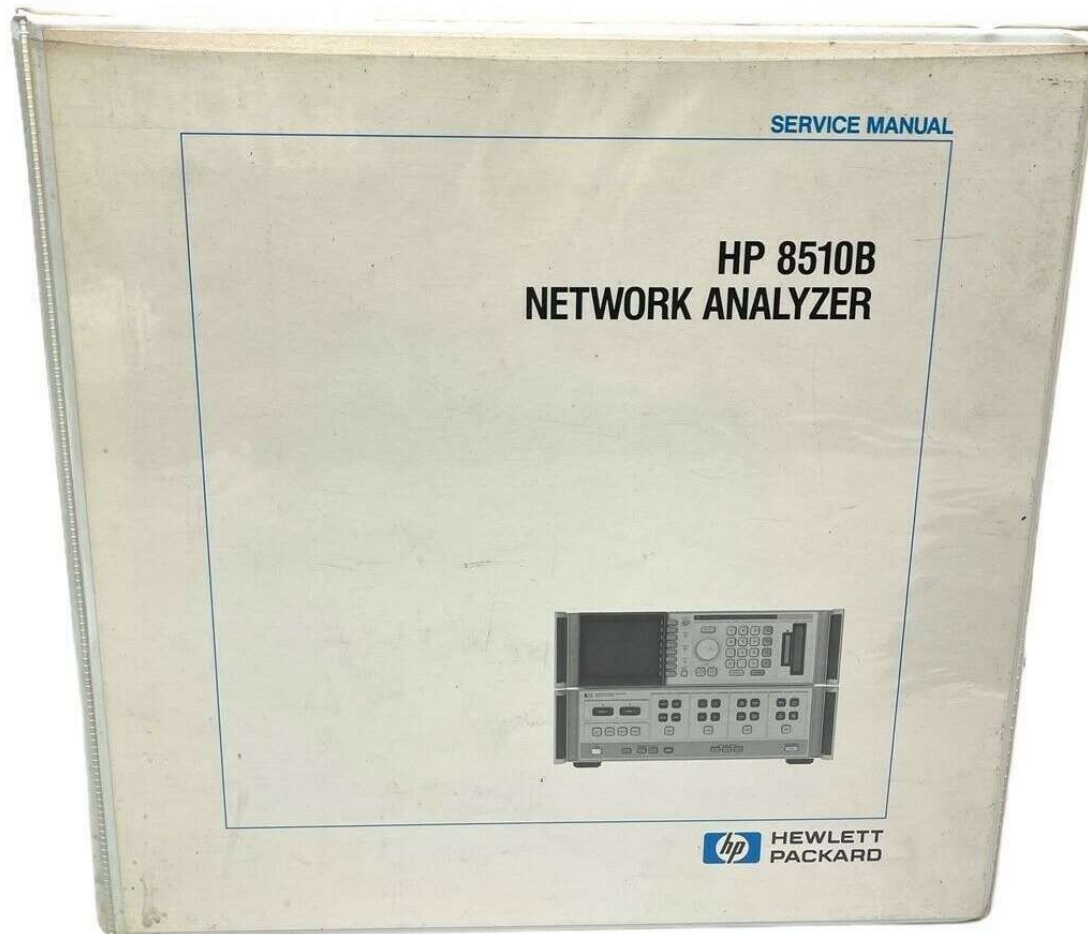

- HP8510B service manual contains no component level schematics
- Schematics of HP8510A partly match.
- Identical Power Supply in HP8510A und B.
- Also NO schematic of switching regulator in HP8510A manual

Only Block Diagram for A7 Switching Regulator

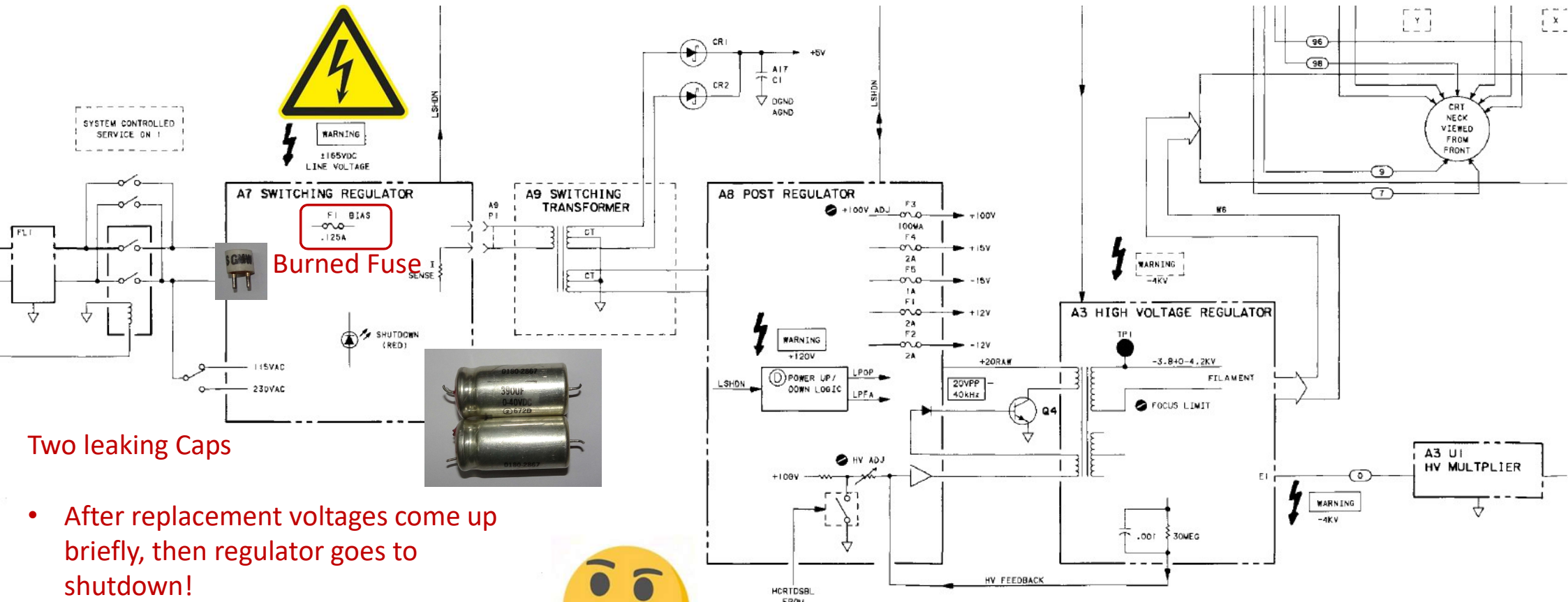

Burned Fuse

Two leaking Caps



- After replacement voltages come up briefly, then regulator goes to shutdown!
- Fuse holds.



Next, long search for more detailed schematics to no avail...

Februar 2017: Test Set arrives from USA



HP8515A 26,5GHz Test Set

Ihr Preisvorschlag von US **\$299,00** wurde akzeptiert! Als Nächstes geht es zum Bezahlen.

Jetzt zahlen

Bitte bezahlen Sie , um Ihren Kauf abzuschließen.

Ihr Artikel - Ihr Erfolg

HP/AGILENT 8515A S-Parameter Test Set

- ... + Transport + Tax
- Fan missing
- Hopefully good investment

This is where all the RF magic happens!



Smoke Signs of different Kind...



- New fan mounted
 - Mains selector to 230V
 - Power-up, 10min later...
- ➔ **Smoke and Stink!**

*X-Capacitor in mains filter
went up in smoke! ☹️*

Mains filter difficult to reach...

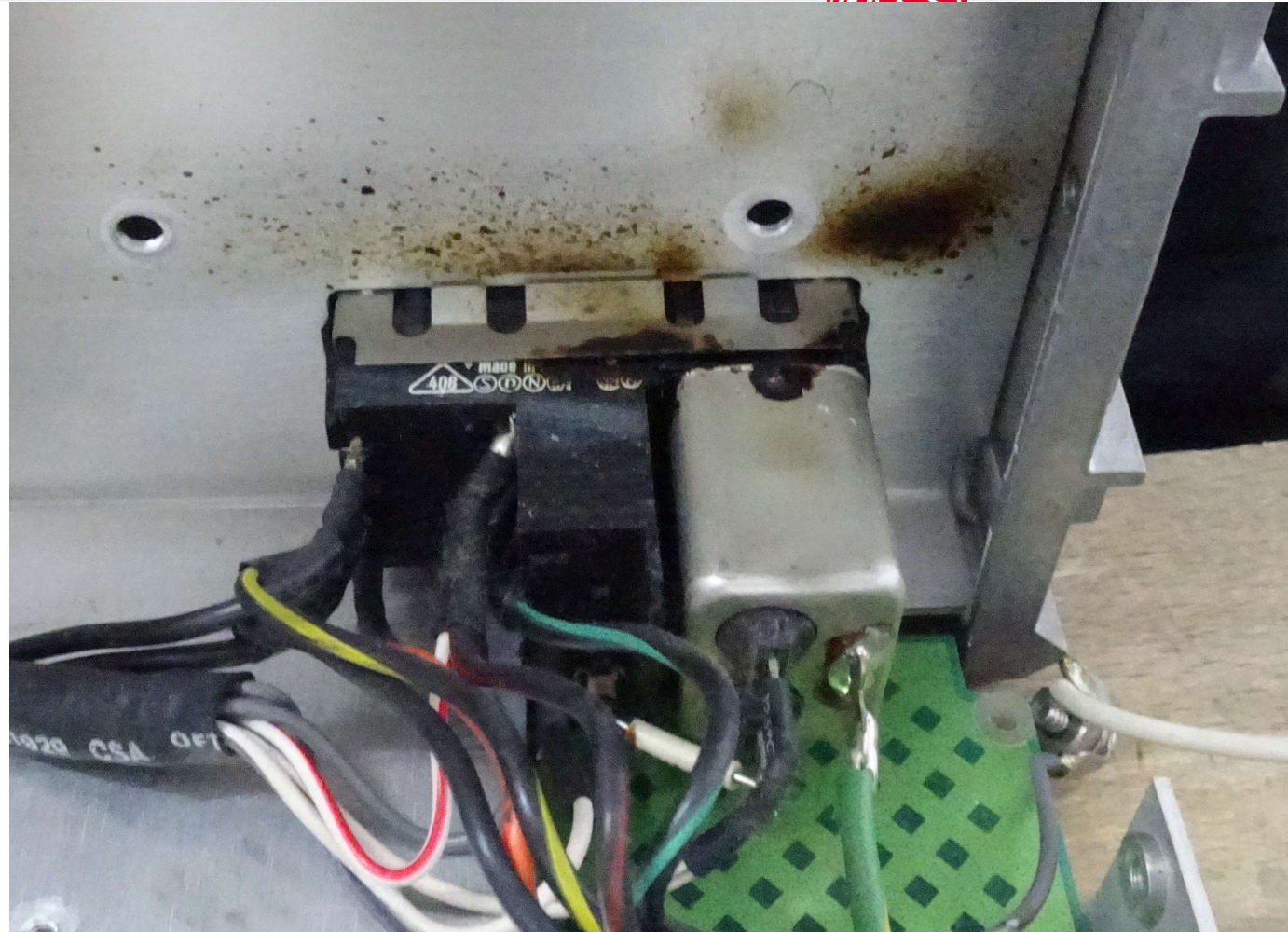

Swap of Mains Filter in HP8515A (1)

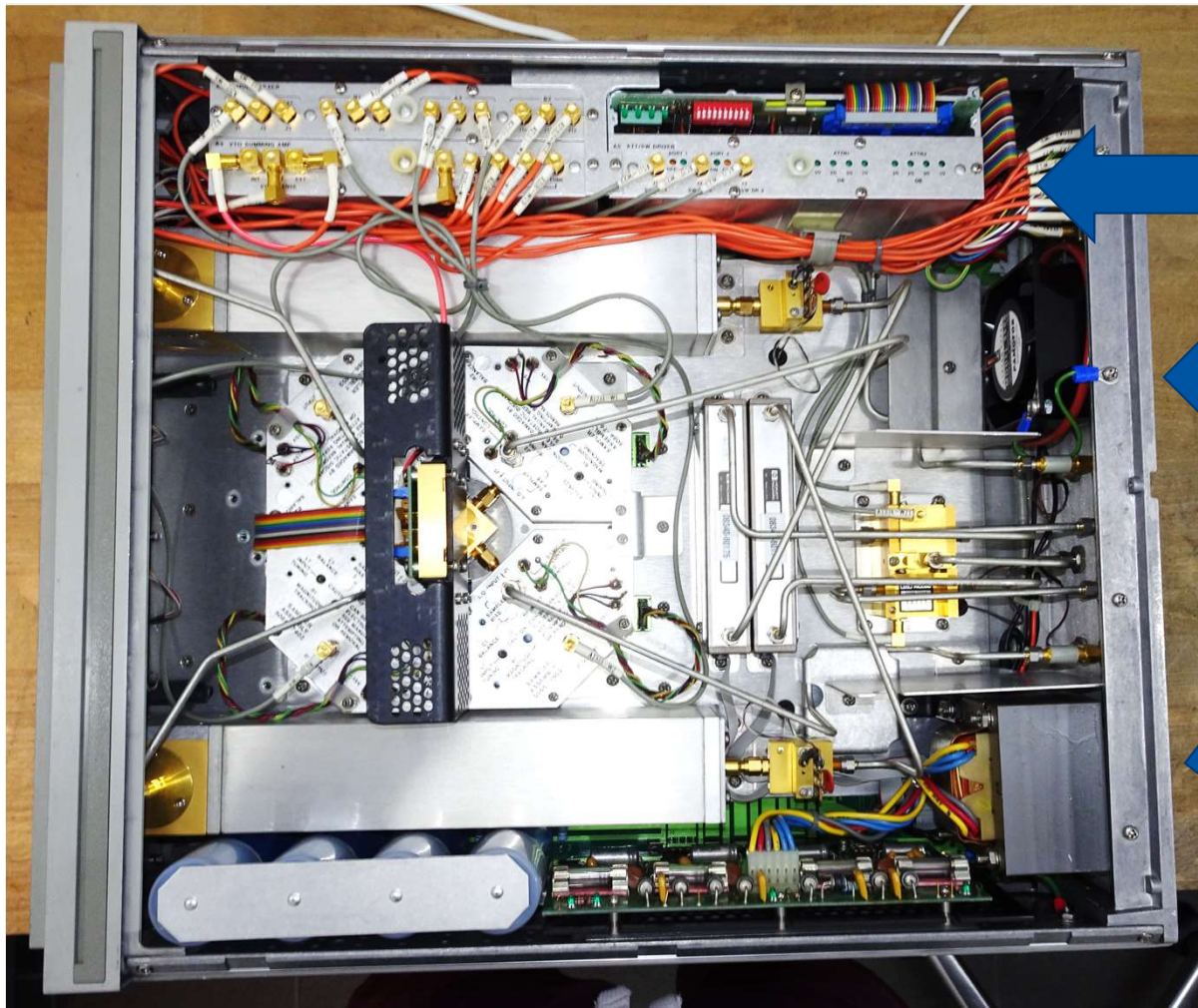

- Remove all cables
- Remove back panel



Mains filter
between
transformer and
motherboard...

Swap of Mains Filter in HP8515A (2)

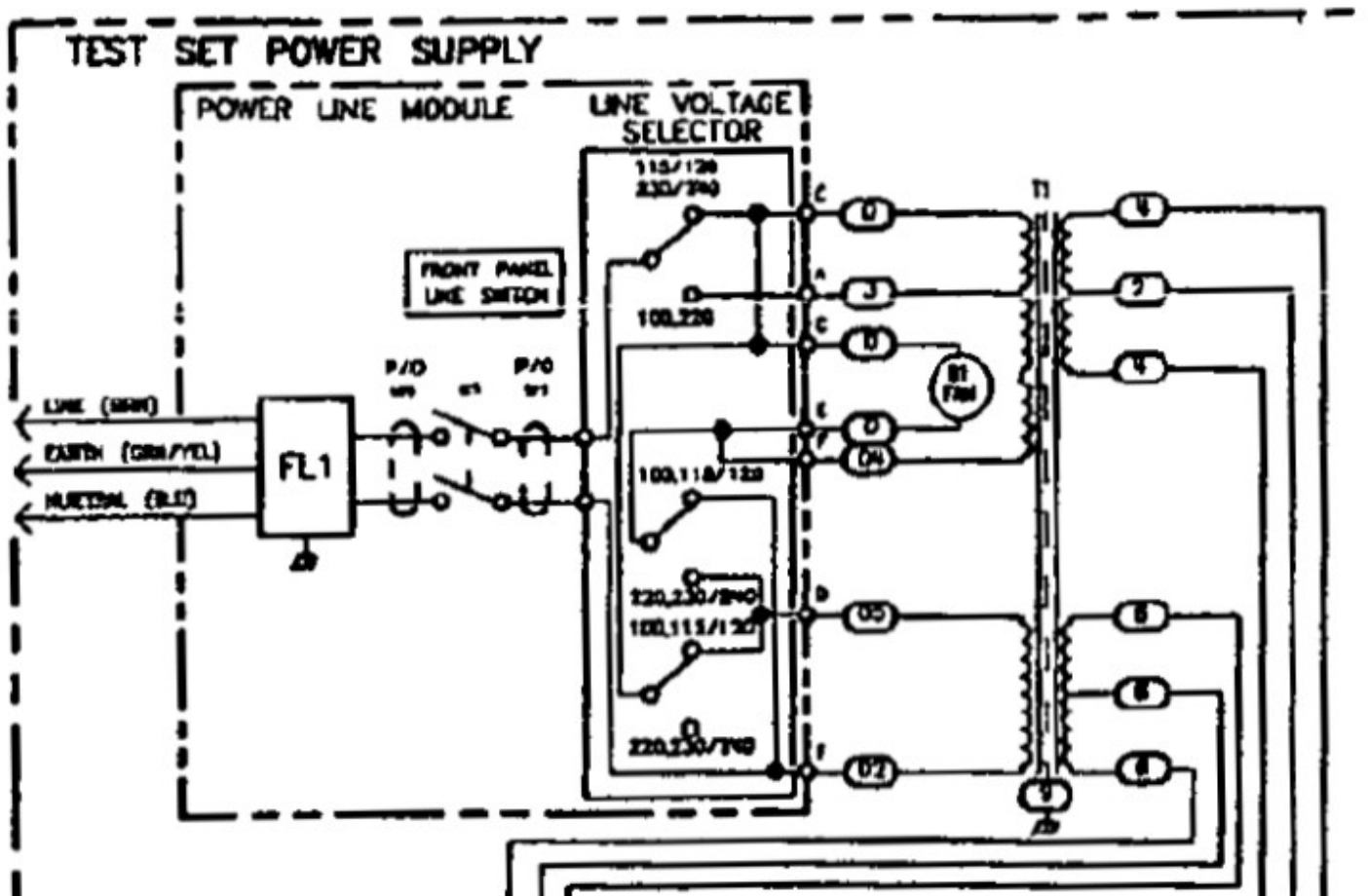

... now, which wire goes where???

Swap of Mains Filter in HP8515A (3)

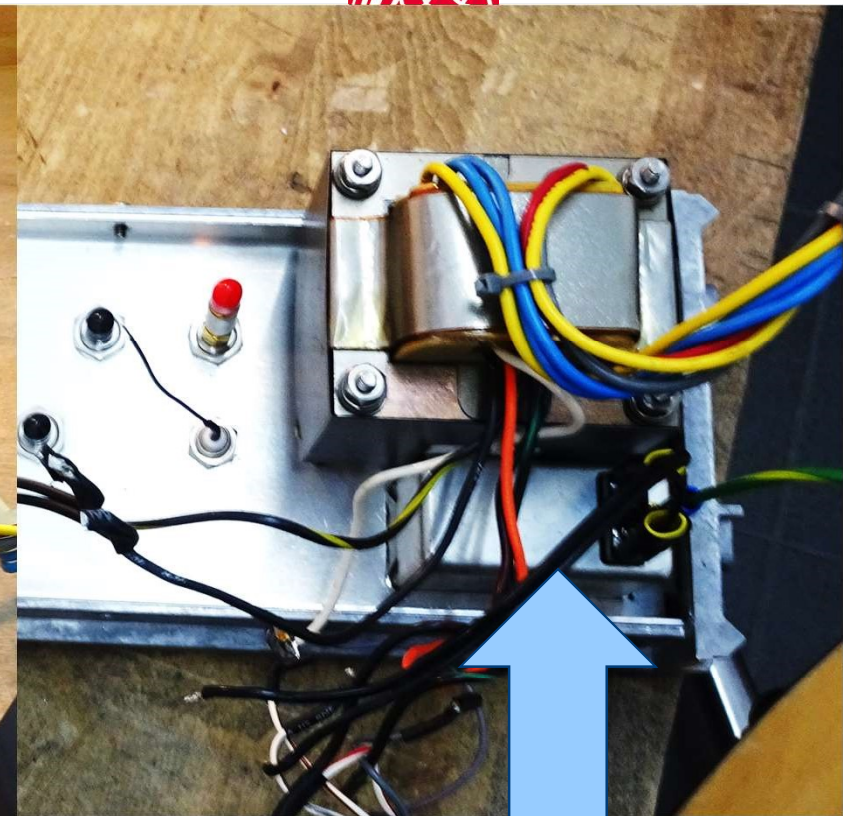
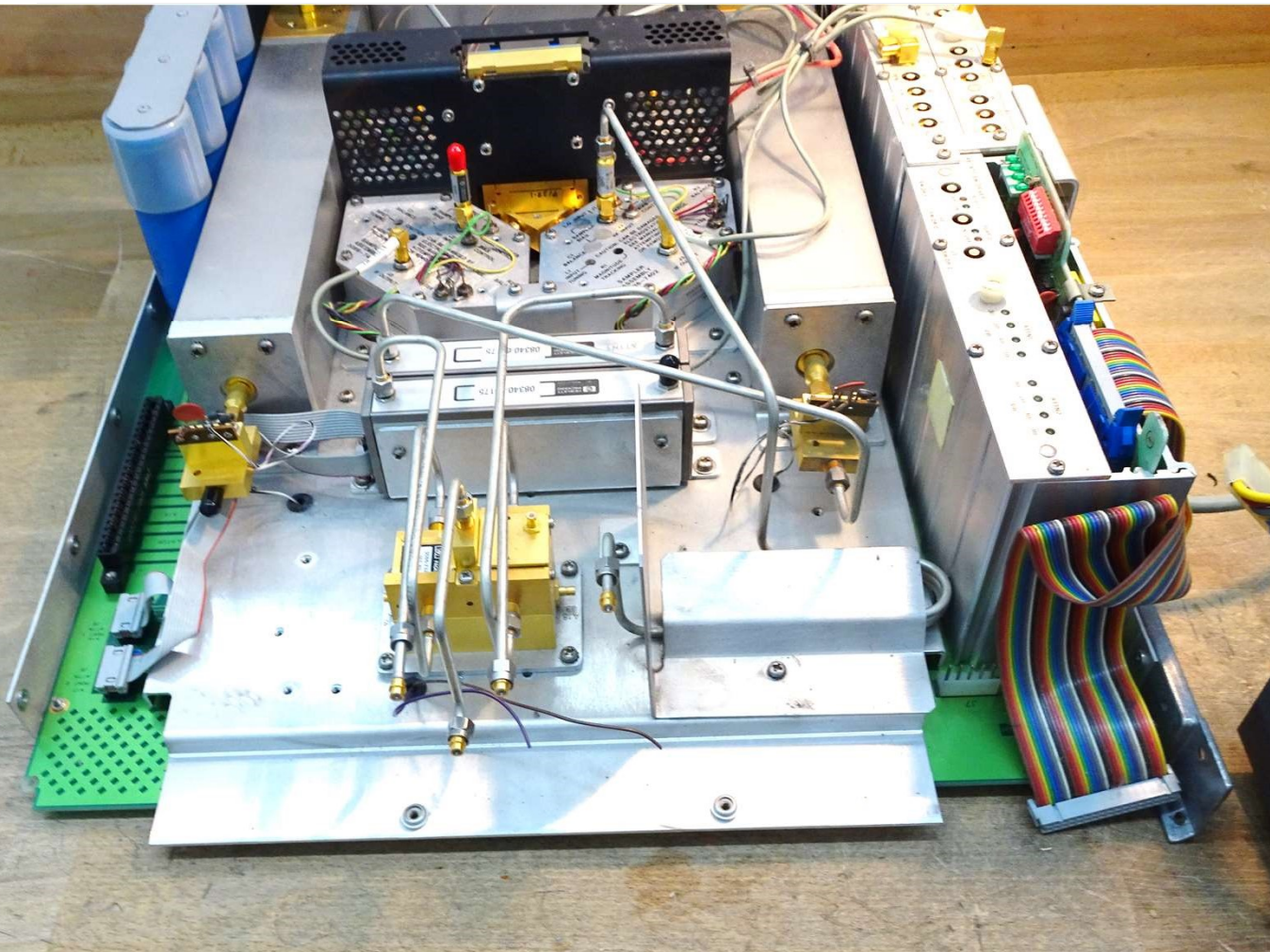

NEW! 😊
But only for 230V!

Pandemia a Chance for new Attempt

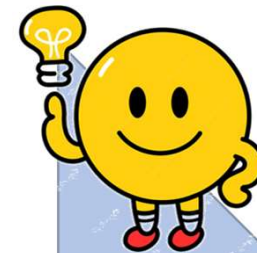

Diskussions with friends

2017

2018

2019

2020

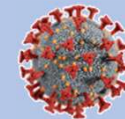

2021

2022

Investigations and many diskussions on HP-Forum

<https://groups.io/g/HP-Agilent-Keysight-equipment>

June 2022: HP85101 Power Supply 2nd Try

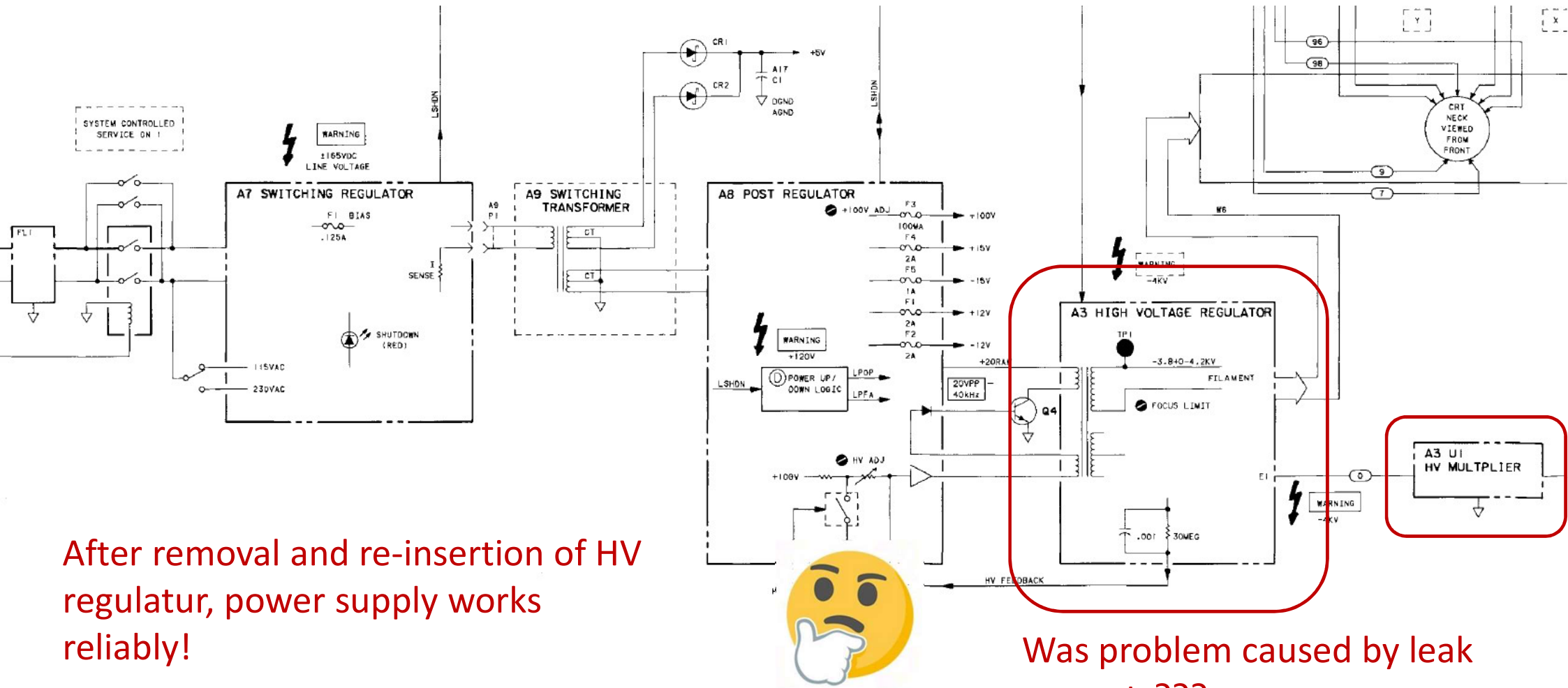

After removal and re-insertion of HV regulator, power supply works reliably!

Was problem caused by leak currents???

HP85101: There's another one!

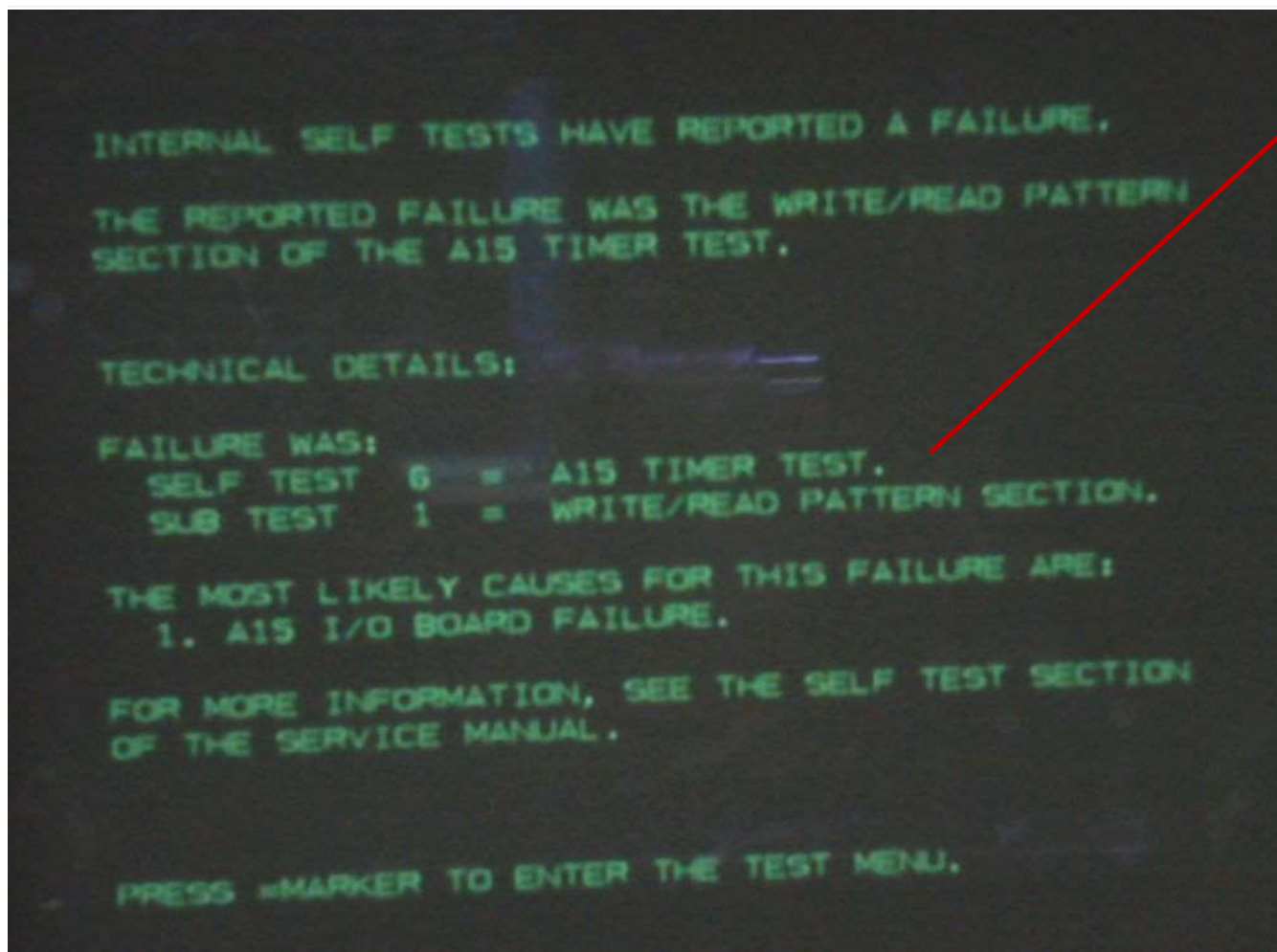

Test 6 – A15 Timer

The processor writes data word Hex 55 (0101 0101) in A15U35. The data is read and compared to communicate with the processor.

...

Probable cause of failure:

- Faulty A15 board.
- Faulty U35 on the A15 board.

• So, U35 on A15 defective!?

And ...

- Cathode of CRT apparently exhausted
- Defective fan!



A stupid Mistake...



Where is board A15?
One of those,
But which one?

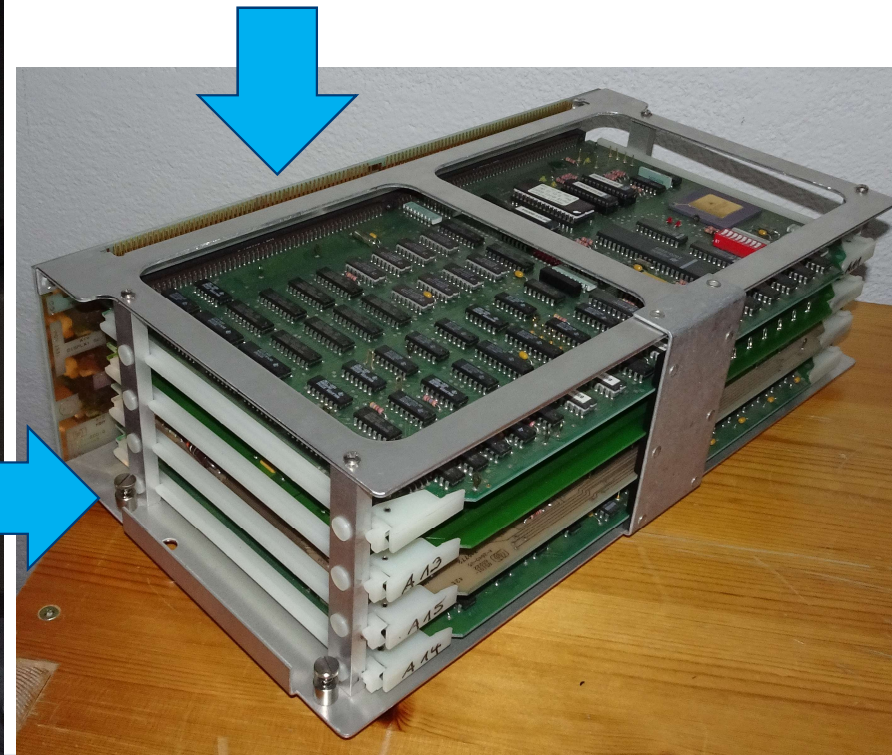

A stupid Mistake...

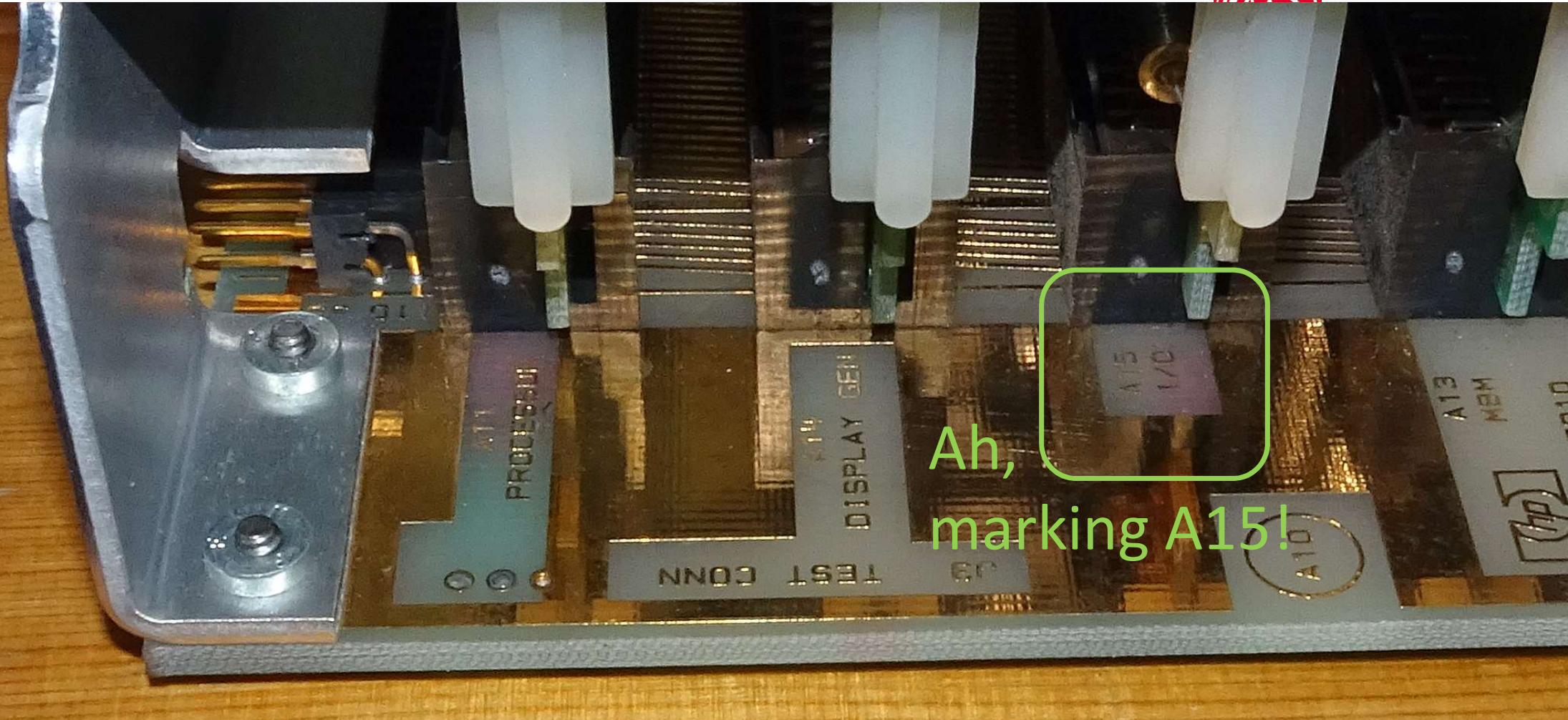

Ah,
marking A15!

A stupid Mistake...

U35?
Ah, it has a socket!
No HP-part
number???

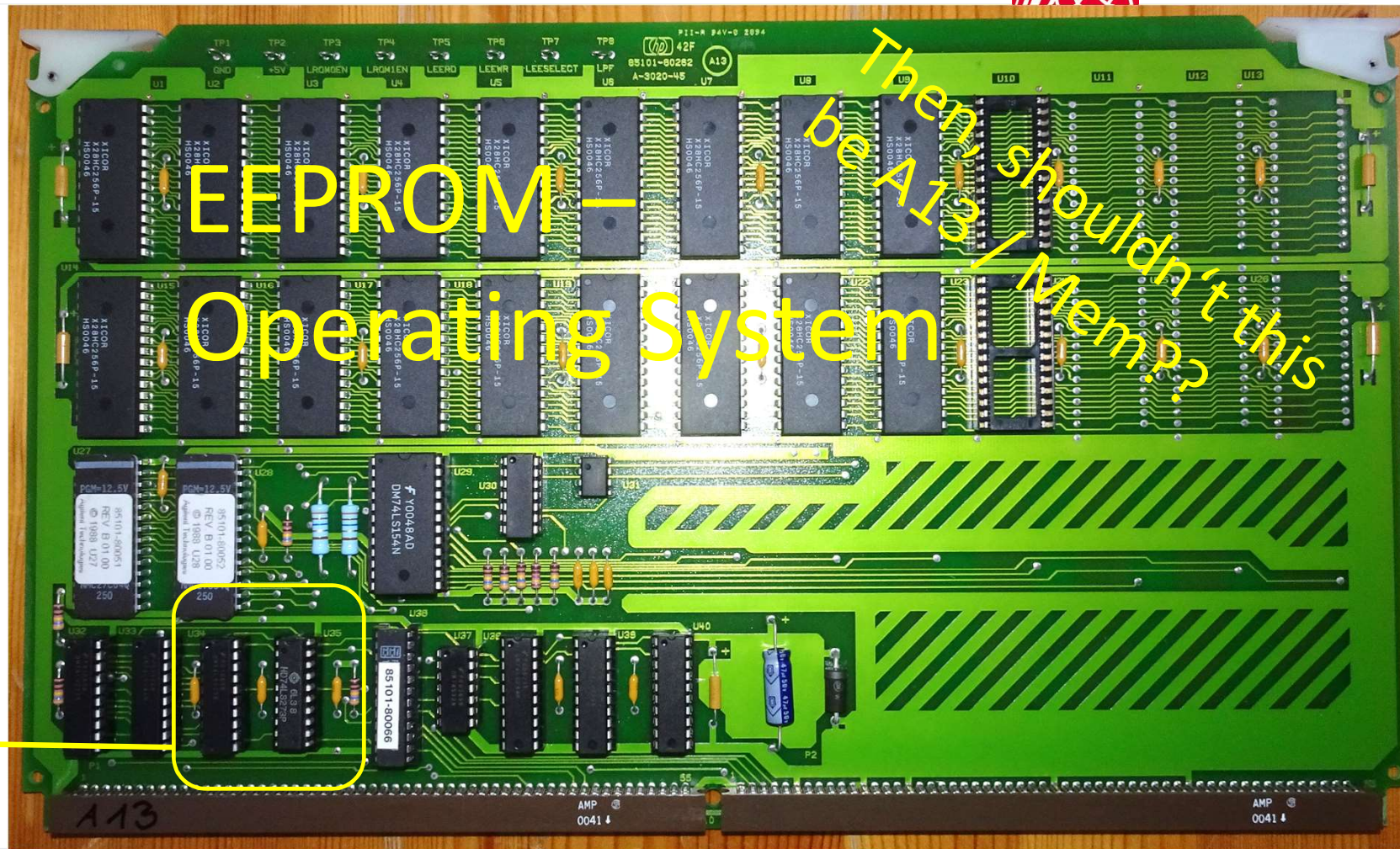
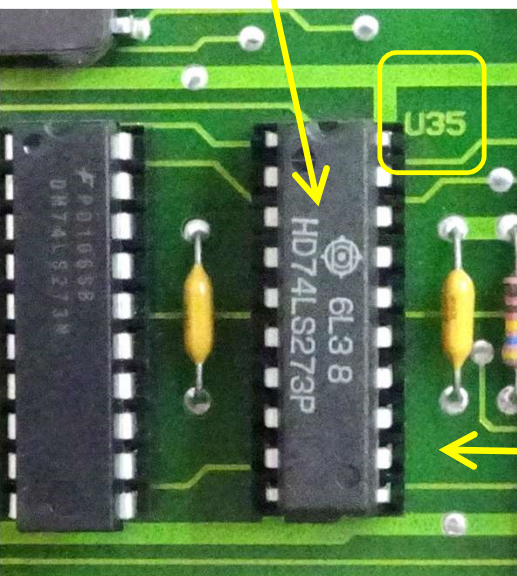

Board was mis-placed in Cage!



The „real“ A15 board !
And defective U35, an Intel Timer-IC, didn't have a socket

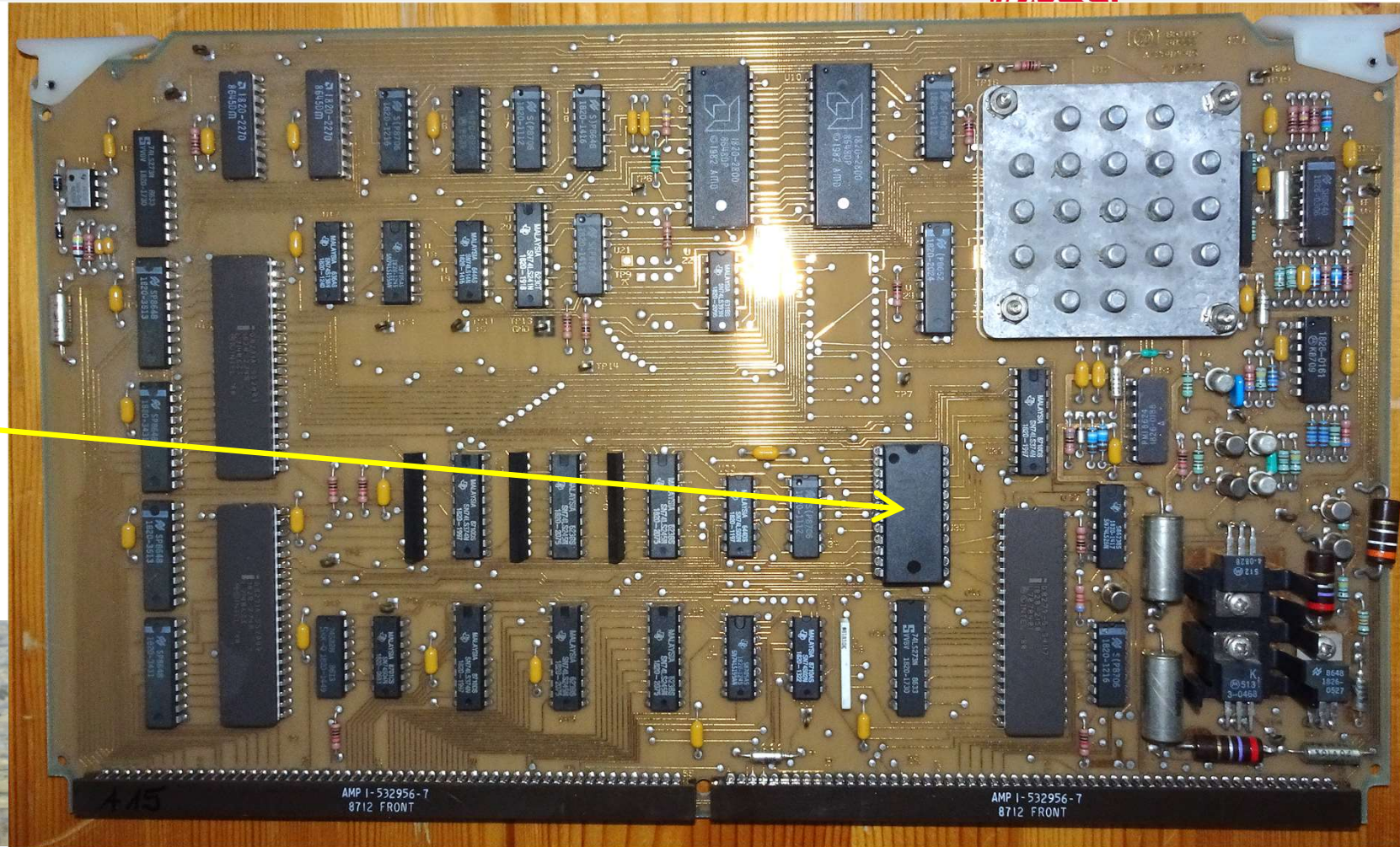

As soon as you do it right...



```
INTERNAL SELF TESTS HAVE REPORTED A FAILURE.  
THE REPORTED FAILURE WAS THE WRITE/READ BIT # D 1  
SECTION OF THE IF DETECTOR DATA TEST.  
  
TECHNICAL DETAILS:  
  
FAILURE WAS:  
SELF TEST 13 = IF DETECTOR DATA TEST.  
SUB TEST 2 = WRITE/READ BIT # D 1 SECTION.  
  
THE MOST LIKELY CAUSES FOR THIS FAILURE ARE:  
1. 85102 INTERCONNECT CABLE MISSING OR DAMAGED.  
2. 85102 A24 FAILURE.  
3. A15 I/O BOARD FAILURE.  
4. 85102 A0 FAILURE.  
5. 85102 MOTHERBOARD OR CONNECTOR OR CABLE FAILURE.  
6. 85101 A17 MOTHERBOARD OR CONNECTOR FAILURE.  
  
FOR MORE INFORMATION, SEE THE SELF TEST SECTION  
OF THE SERVICE MANUAL.  
  
PRESS #MARKER TO ENTER THE TEST MENU.
```

So far so good!
IF-Detektor HP85102 not
connected yet.



Need interconnect cables!

\$\$\$!!!



Homebrew Interconnect Cables

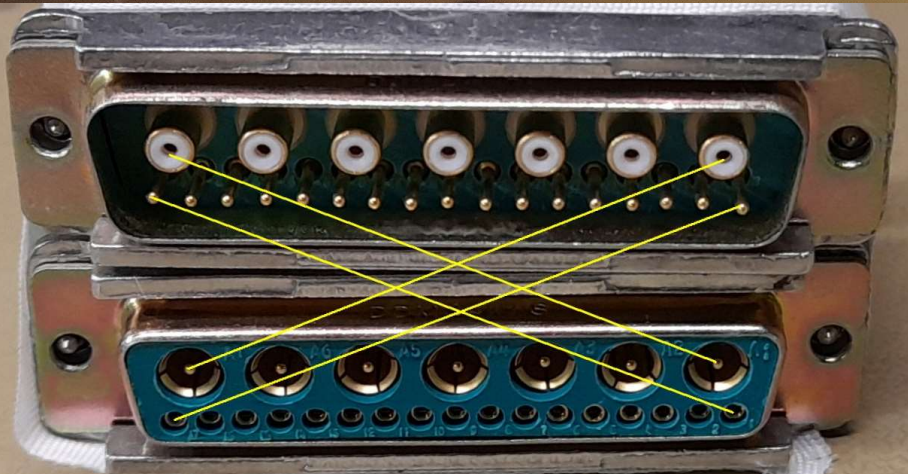

1:1 Thru Connections



Special thanks to Jan G5BBL for obtaining the connectors!

HP85102 IF Unit



Someone else had already messed around with this!
Two „bad“ stickers and loose coax cables!

Two of four IF mixers show too low levels!

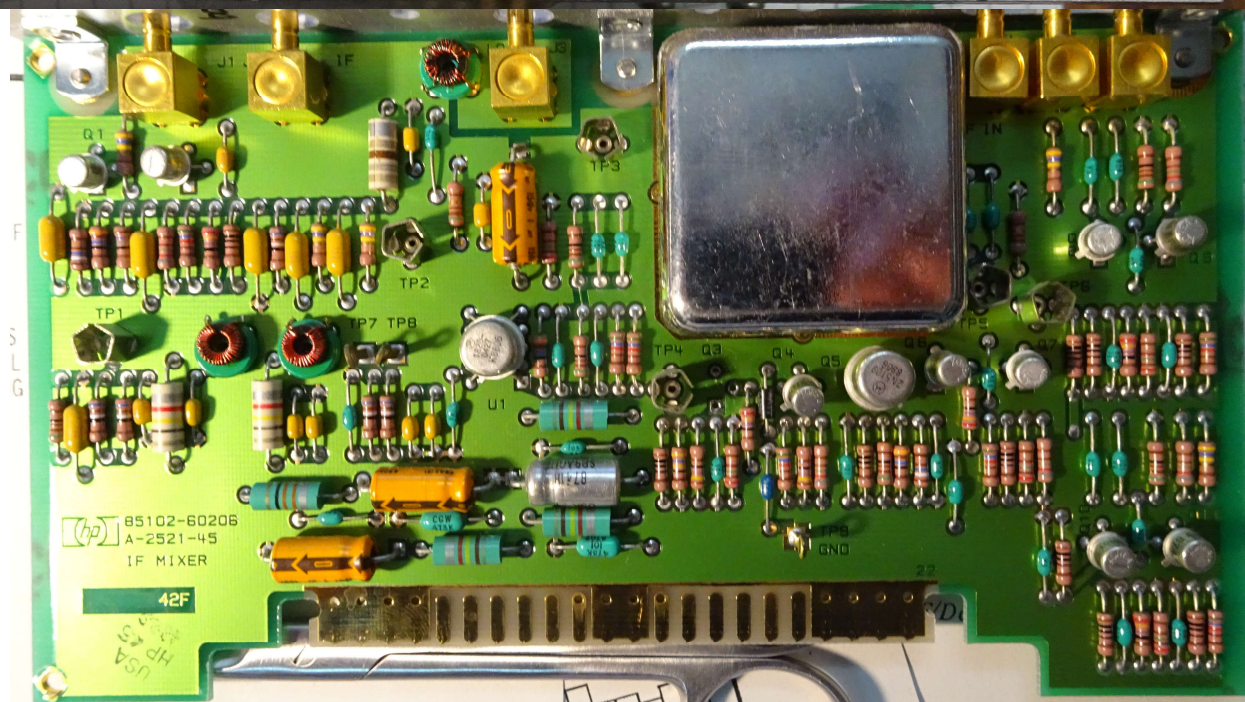

HP85102 IF-Mixer Reverse Engineering ...

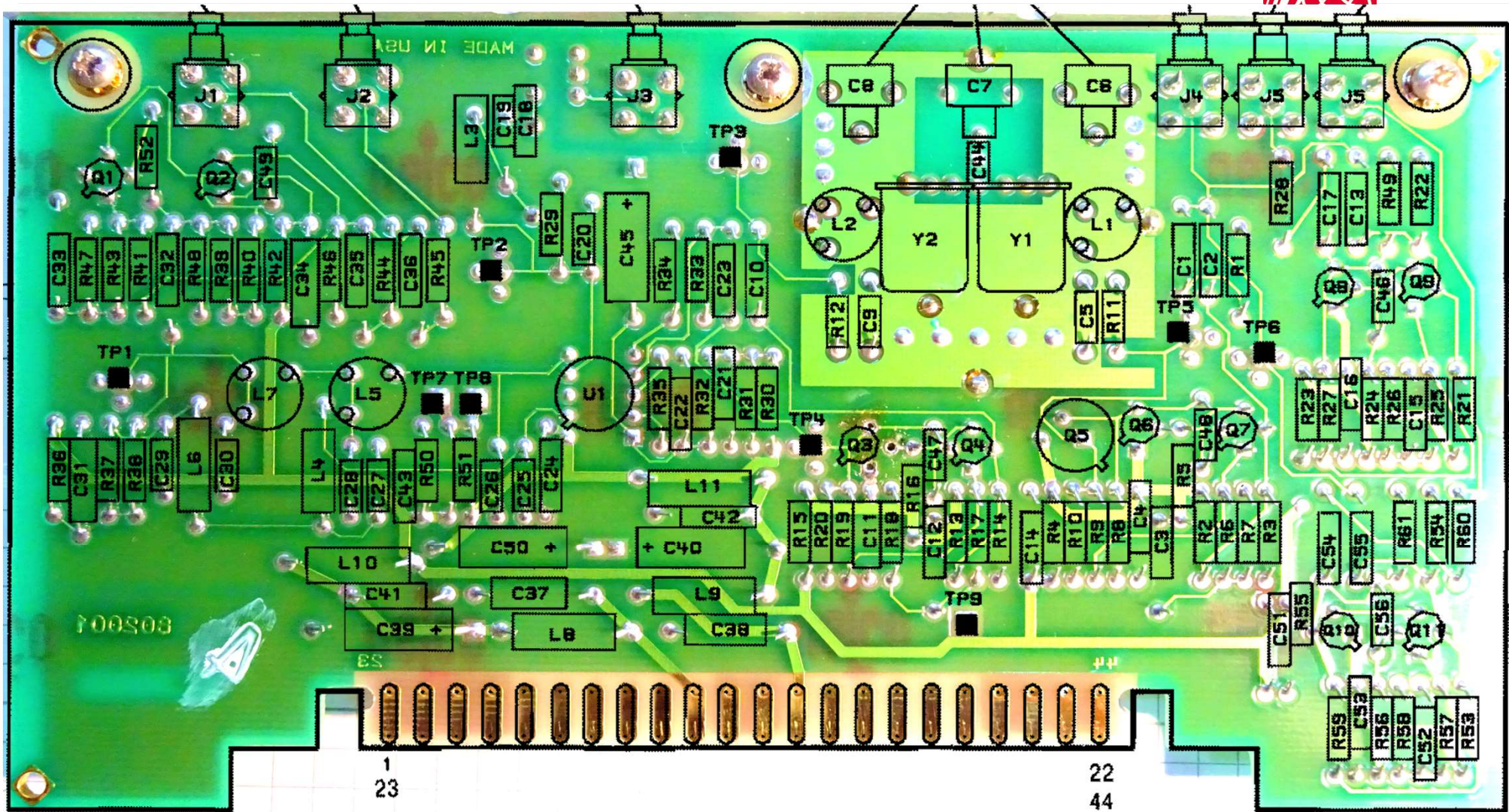

Standard Gain Block

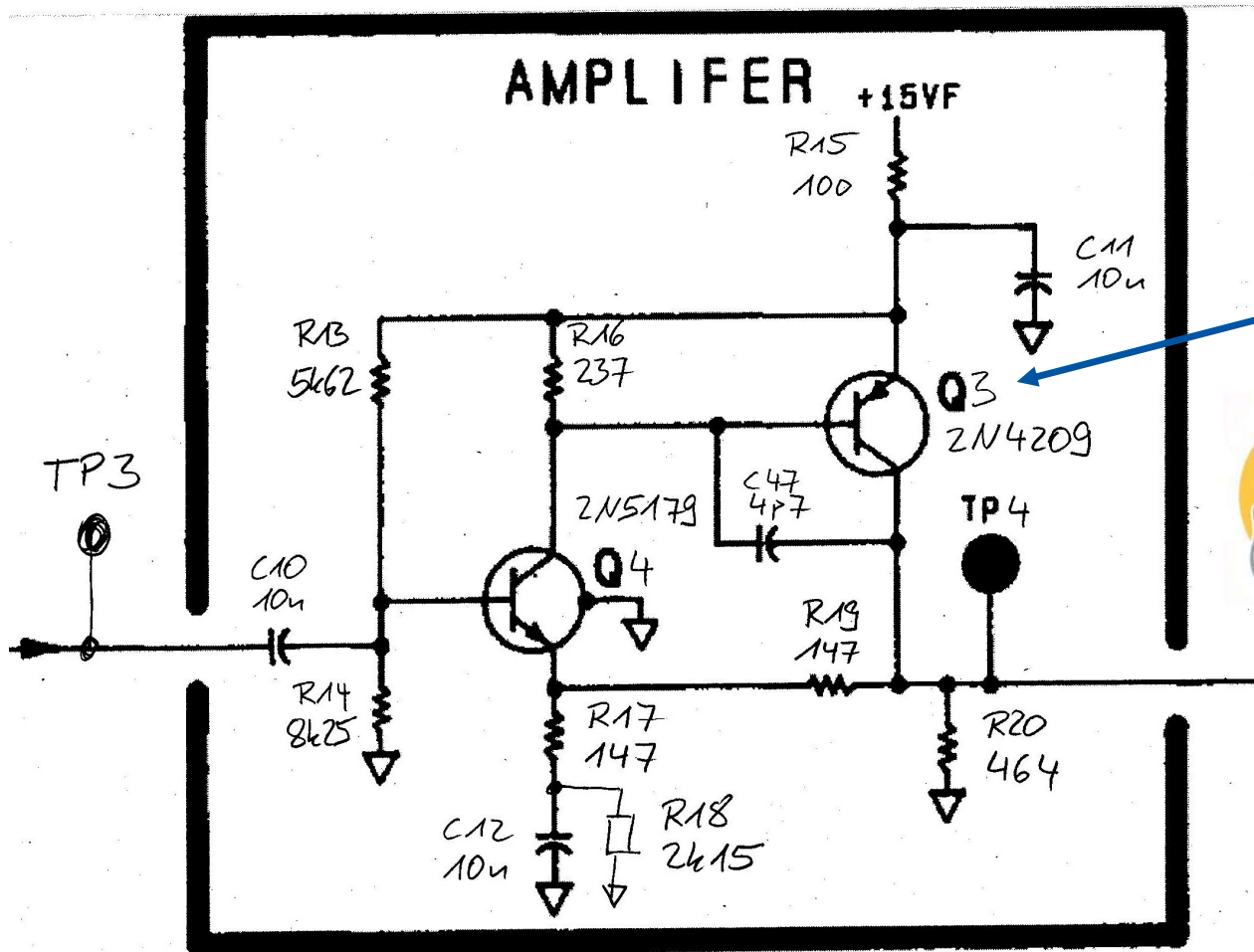

- dc-levels unsuspecting
- 6dB higher gain after replacement of PNP transistor!



All PNP transistors on all mixer boards replaced!

2N4209 PNP Transistors

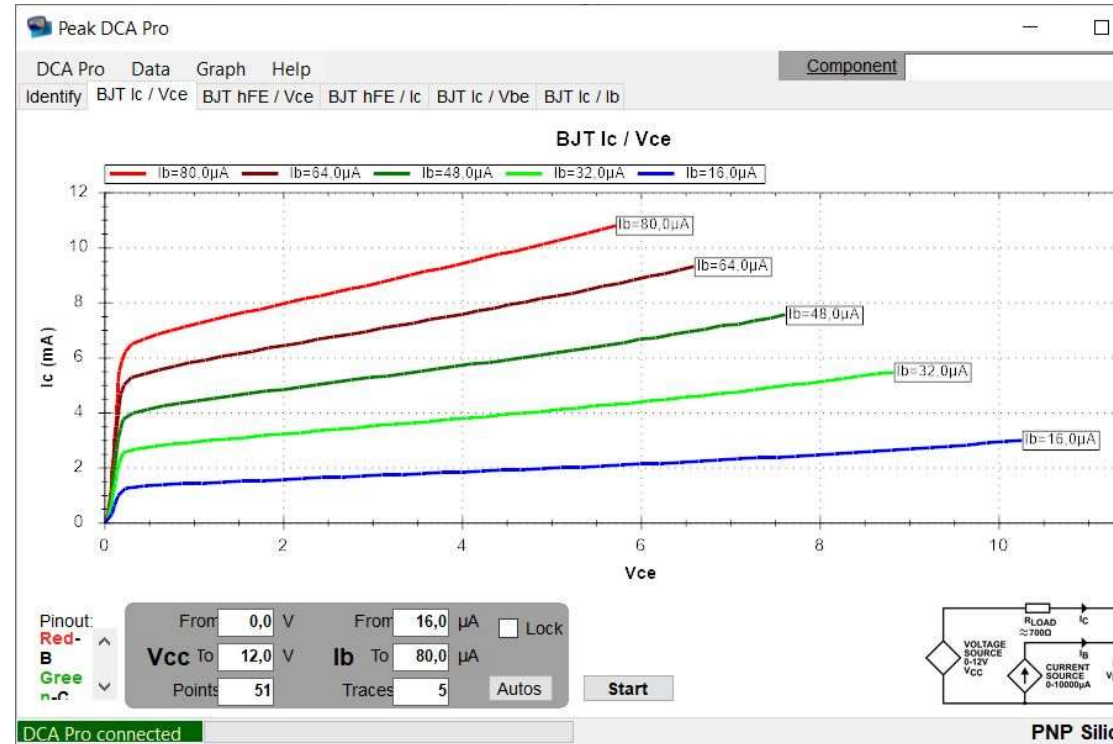
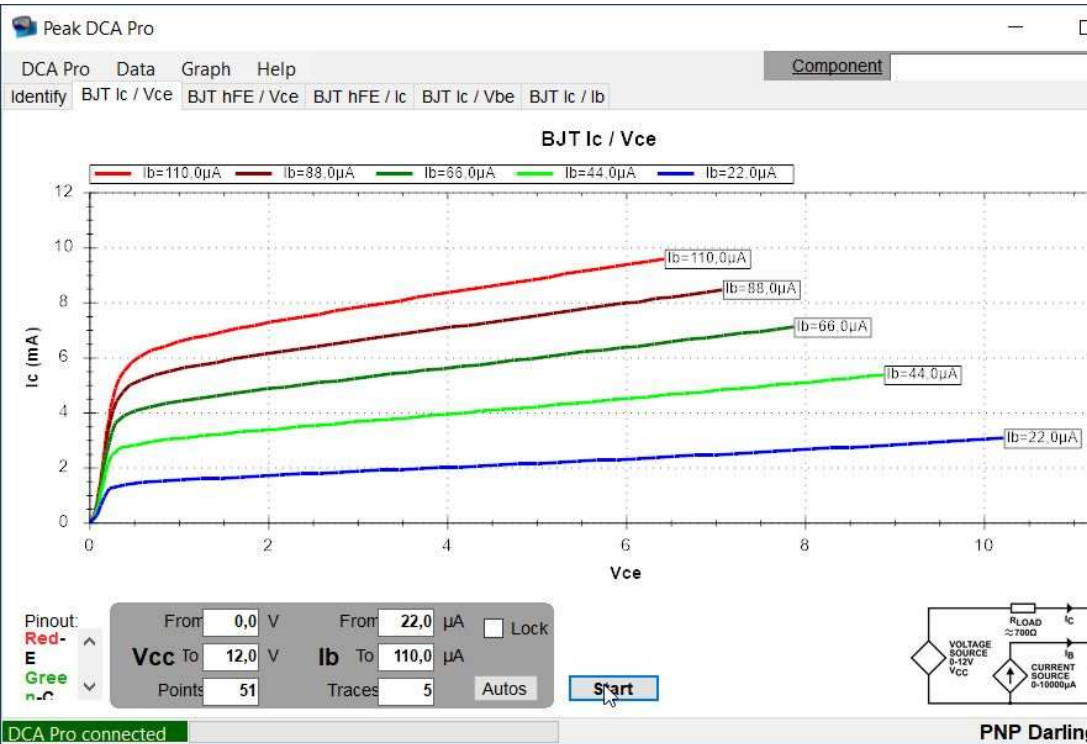

BAD

GOOD

Slightly different current gains

Sign of Live

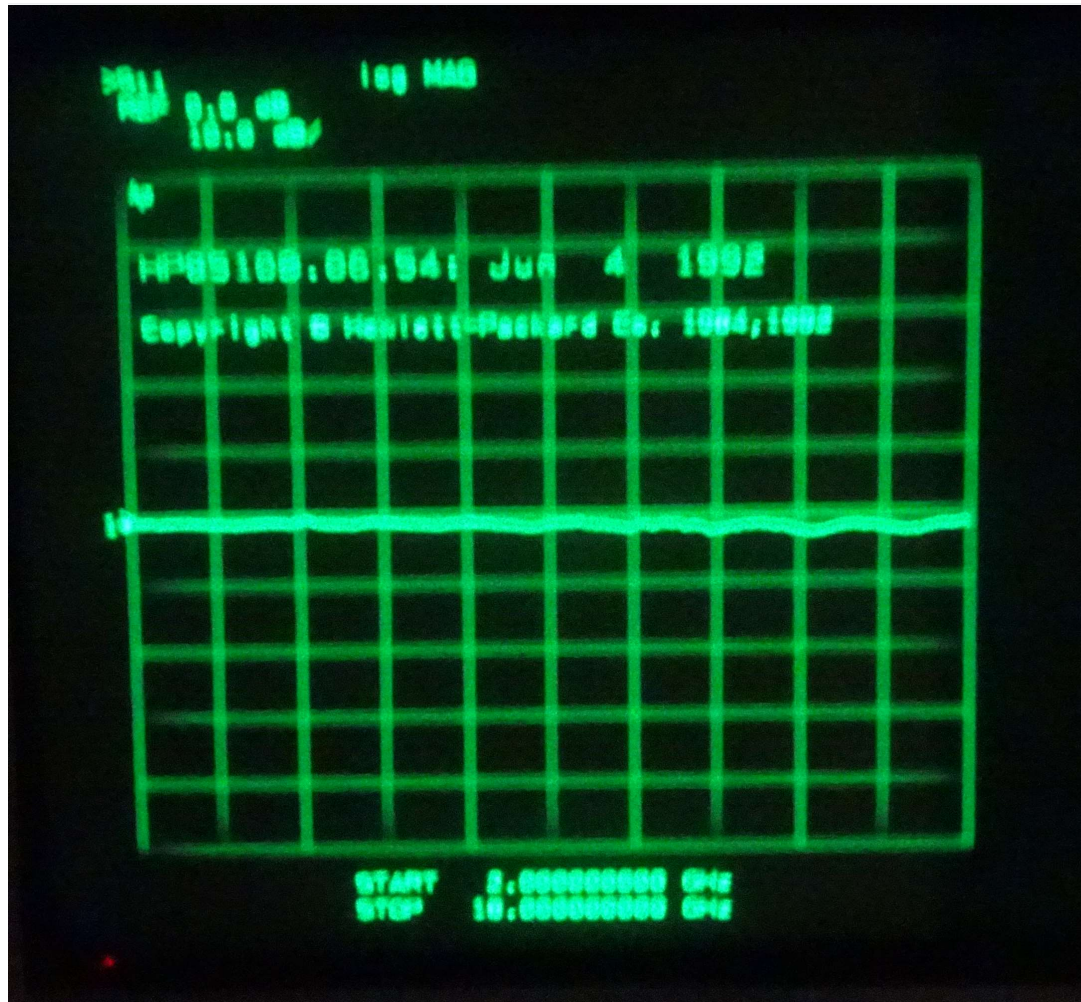

- Display unit technically ok
- IF unit operational
- Test set operational



Screen image either fairly bright OR crisp but never both at the same time
⇒ CRT wants to be regenerated, see <http://www.ke5fx.com/crt.html>

How to move 200 Pounds of Test Equipment?



T. Baier DG8SAQ, Juni 2023

How to transfer measured Data?



via GPIB interface!

Arduino AR488 GPIB-Adapter with
HC06 Bluetooth Interface

<https://github.com/Twilight-Logic/AR488>

Screenshots readable with KE5FX
GPIB Tool-Kit

<http://www.ke5fx.com/gpib/readme.htm>

VNA can be operated via software
plug-in for DG8SAQ VNWA Software

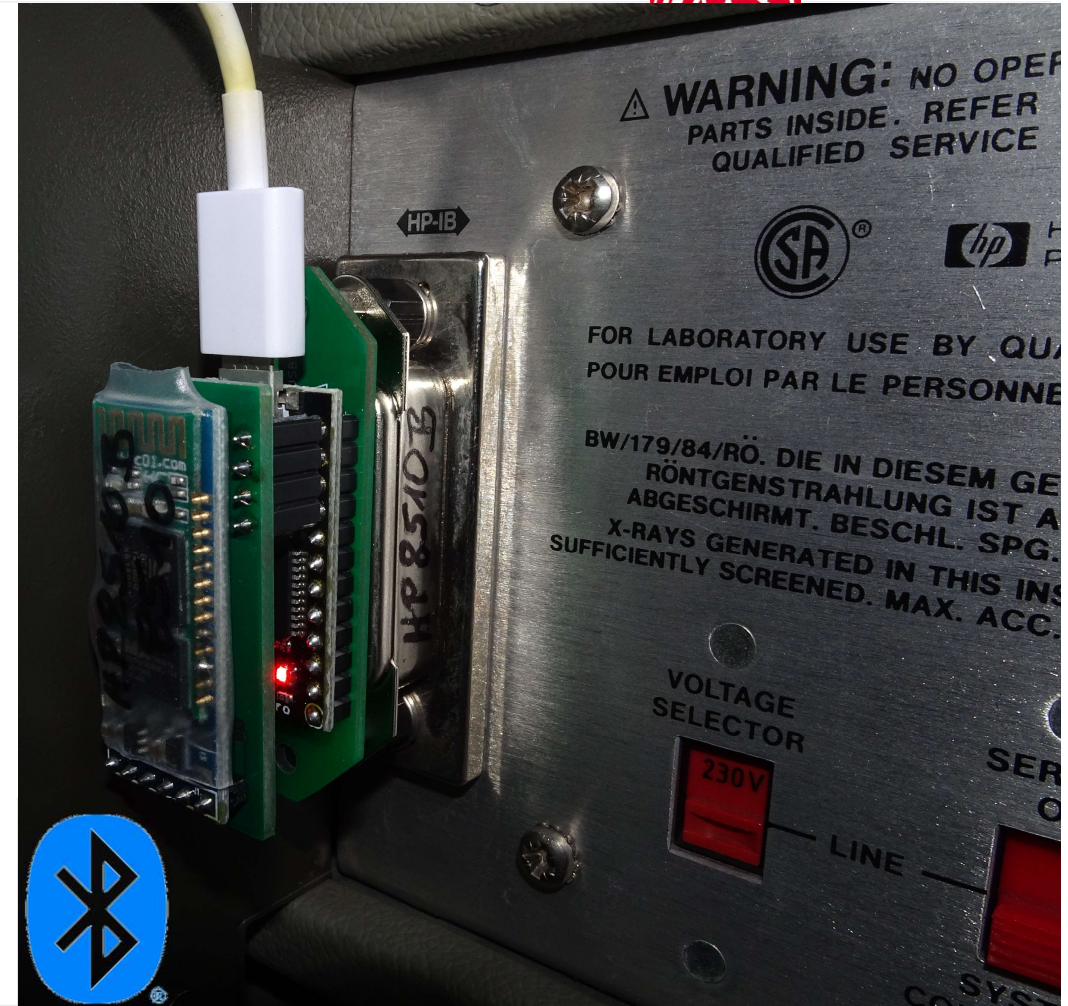

First Test: HP8510B vs. DG8SAQ VNWA3



DG8SAQ Vector Network Analyzer Software

02.11.2022 07:55:28 435MHz SAW: Sij: HP8510B, Plot*: VNWA3SE, Rosenberger cal kit

IG8SAQ Vector Network Analyzer Software

2.11.2022 07:54:21 435MHz SAW: Sij: HP8510B, Plot*: VNWA3SE, Rosenberger cal kit

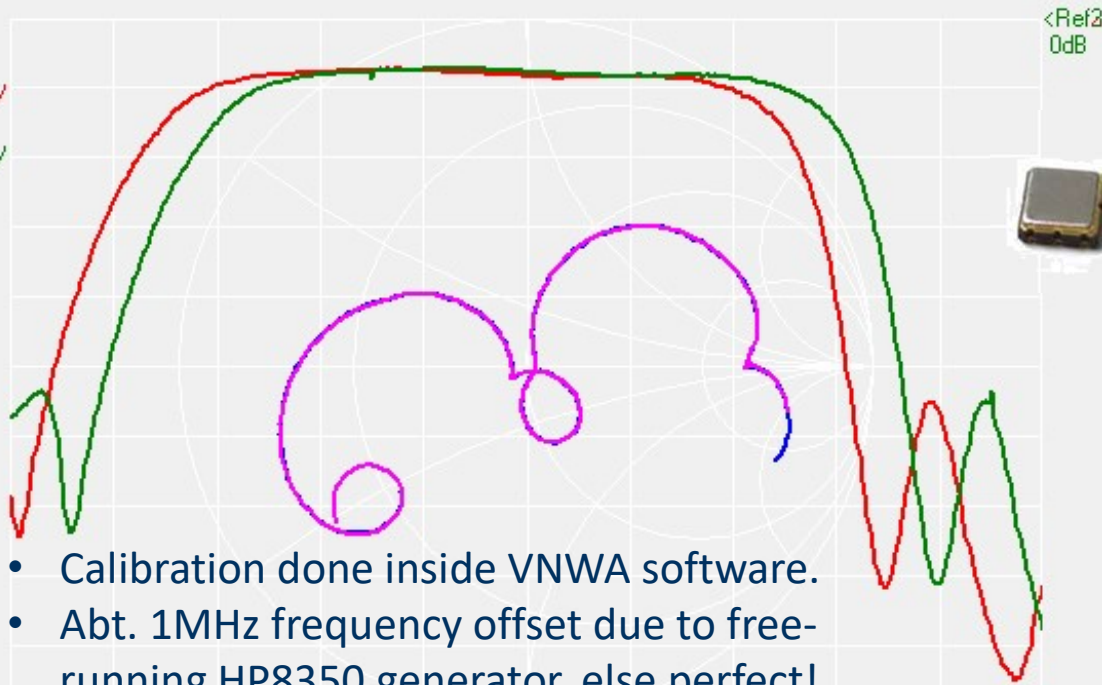

- Calibration done inside VNWA software.
- Abt. 1MHz frequency offset due to free-running HP8350 generator, else perfect!

Start = 425 MHz Center = 435 MHz Stop = 445 MHz

S11 Smith Plot1 dB
S21 dB Plot2 Smith

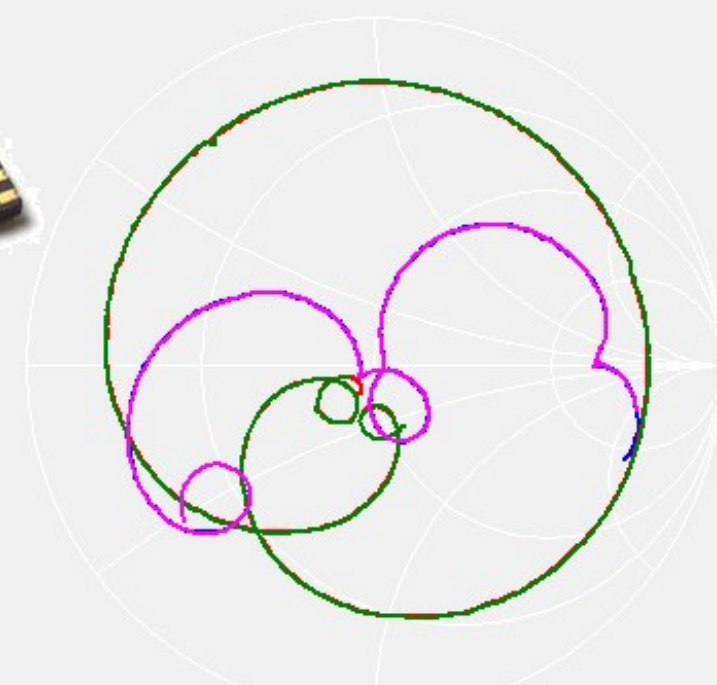

Start = 425 MHz Center = 435 MHz Stop = 445 MHz

S11 Smith Plot1 Smith
S21 Smith Plot2 Smith

HP8510B vs. PicoVNA up to 6GHz



DUT = open transmission line

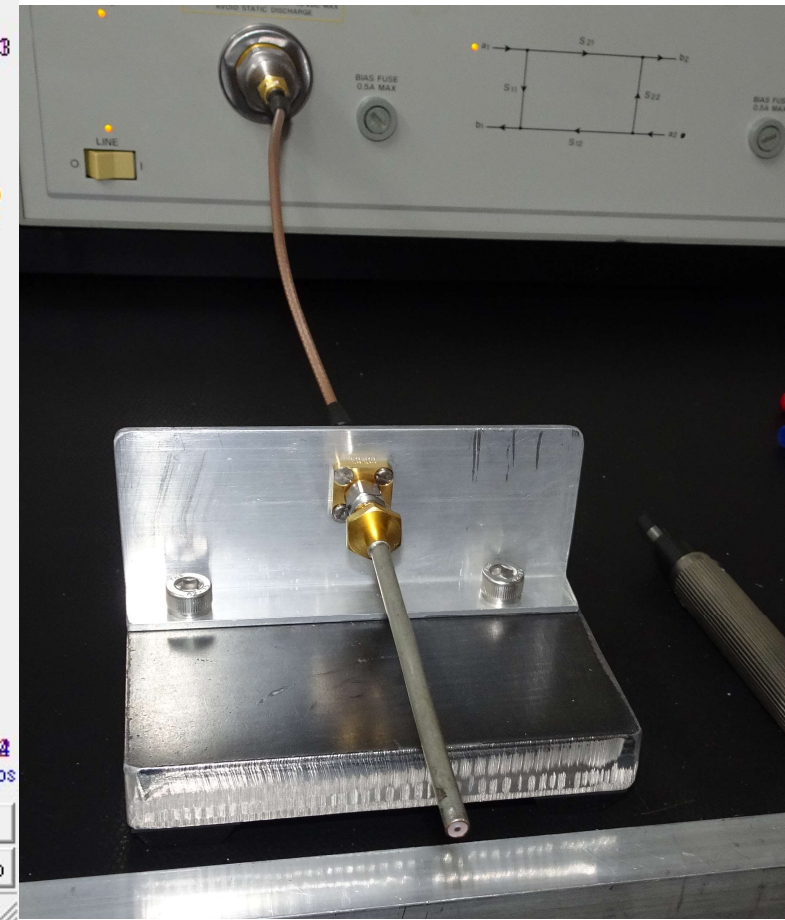
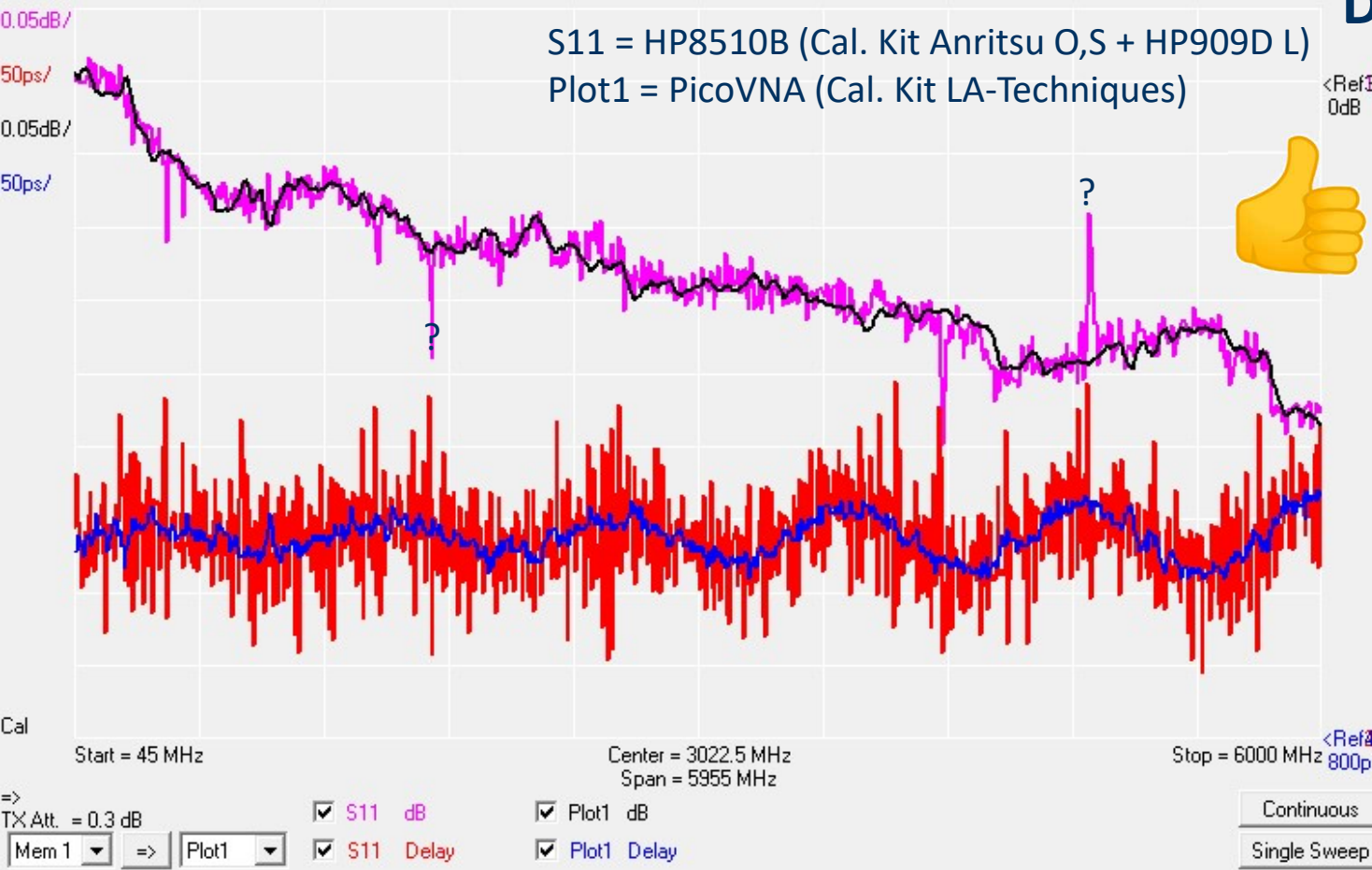

Extrapolation of Calibration to 26,5 GHz (1)



Problem: HP909D Load:



- Extrapolation invalid above 6GHz.
- Above 6GHz no load data available.
- HP8510 Cal Kits assume Load as *ideal!*



Extrapolation of Calibration to 26,5 GHz (2)

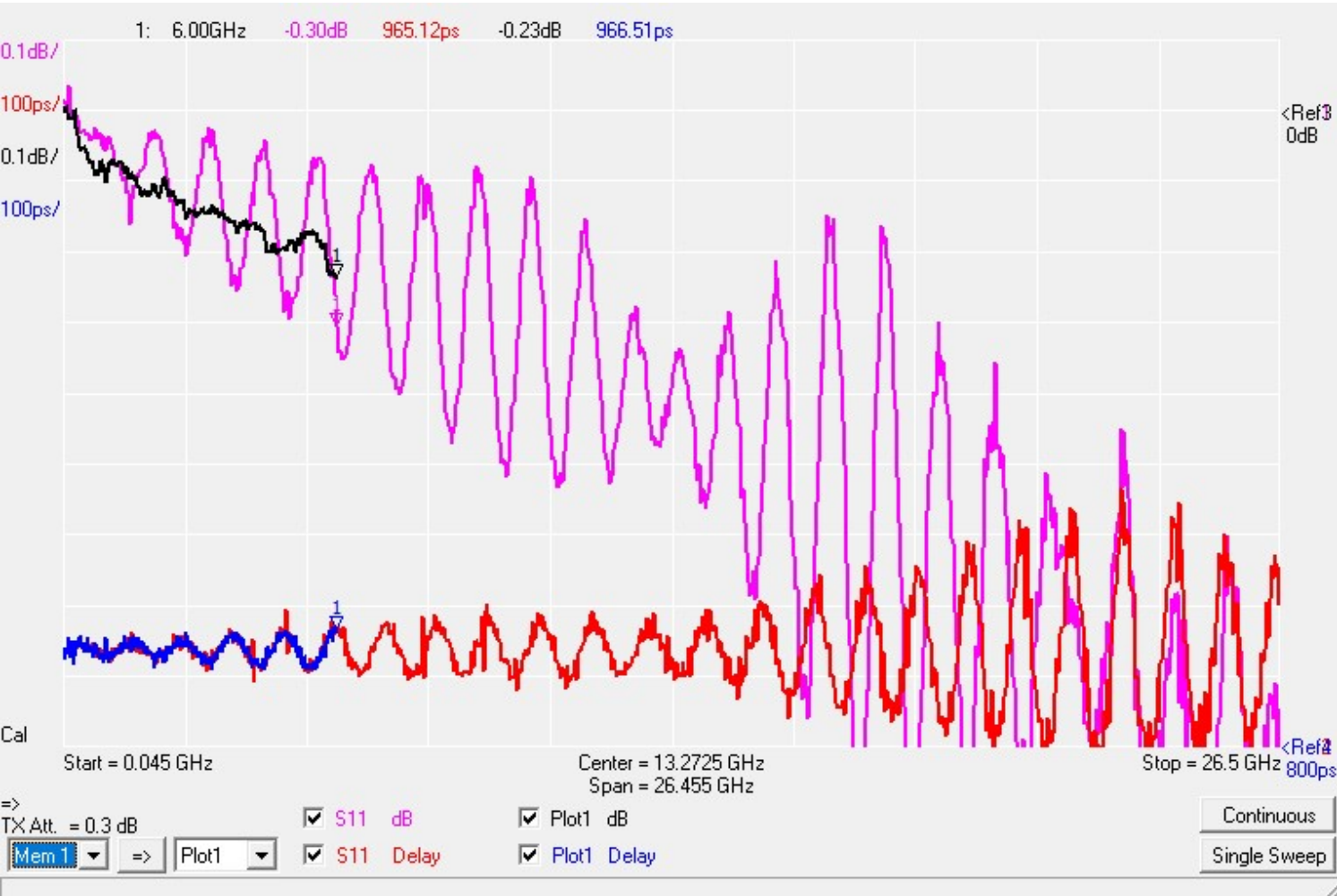

Ideal load assumed:



S=0

- Worse below 6GHz
- Better above 6GHz



- *HP909D should be compared to a good commercial cal-kit.*
- *An air-line would make a superior DUT.*

Extrapolation of Calibration to 26,5 GHz (3)



1: 6.00GHz -0.64+i0.73 -0.65+i0.73



BUT...

- We are talking about an error of $\pm 0,3dB$ for a highly reflecting DUT up to 26,5GHz!
- Error hardly noticable in Smith-chart.



Quite satisfactory for hobby use!

Cal

Start = 0.045 GHz

Center = 13.2725 GHz
Span = 26.455 GHz

Stop = 26.5 GHz

=>
TX Att. = 0.3 dB

S11 Smith

Plot1 Smith

Continuous

Mem 1 => Plot1

Single Sweep

Summary



- *Successful repair of HP8510B*
- *Was time consuming and at times stressful*
- *Still a very exciting and satisfying project*
- *Affordable for amateurs*



Many thanks for your interest!



Another repair job

CAUTION



BIOHAZARD

Why is the satellite dish deaf?!?

